

Honeywell

MAXON

Series 8000 Air Actuated Valves for liquid service

INSTRUCTION MANUAL



Please read the operating and mounting instructions before using the equipment. Install the equipment in compliance with the prevailing regulations.



Bedrijfs- en montagehandleiding voor gebruik goed lezen! Apparaat moet volgens de geldende voorschriften worden geïnstalleerd.



Lire les instructions de montage et de service avant utilisation! L'appareil doit impérativement être installé selon les réglementations en vigueur.



Betriebs- und Montageanleitung vor Gebrauch lesen! Gerät muß nach den geltenden Vorschriften installiert werden.

European Sales Office

BELGIUM

MAXON International BVBA Luchthavenlaan 16-18

1800 Vilvoorde, Belgium

Tel: 32.2.255.09.09

Fax: 32.2.251.82.41



32M-95003-03

Table of contents

Series 8000 Air Actuated Valves for liquid service	1
Features & Benefits	3
Switch Assemblies	4
Body and Trim Selections	4
AGENCY APPROVALS AND CERTIFICATIONS	6
Valve cycle requirements	6
VALVE MODEL NUMBER DESCRIPTION	7
VALVE BODY ASSEMBLY OPTIONS & SPECIFICATIONS	8
Maximum operating pressure ratings	9
Valve Body Capacities with #2 Oil	10
Minimum required cylinder pressures	12
Accessories	16
Speed Control Set Kits	16
Component identification	17
Installation	18
Operating characteristics	19
Auxiliary Features	19
Operating Environment	19
Electrical Data	20
Normally-Closed Shut-Off Valves	20
General Purpose Normally-Closed Valves	20
Class I, Div. 2 Hazardous Location Normally-Closed Valves	20
Class I, Div. 1 and ATEX Zone 1 Intrinsically Safe Hazardous Location Normally-Closed Valves	20
Class I, Div. 1 and ATEX Zone 1 Intrinsically Safe Hazardous Location Normally-Closed Valves	21
Actuator Assembly Rotation/Replacement	22
Field Installation of Valve Position Switch	24
Field Replacement Items	24
Replacement Switches	24
Add Switches	24
Operating Instructions	26
Alternate operator pressures	26
Maintenance Instructions	26
Solenoid replacement procedure	27

Features & Benefits

MAXON Series 8000 Air Actuated Valves combine a unique space-saving design with a maintenance-free body and a replaceable actuator for easy installation and smooth, trouble-free operation.

The valve's quick exhaust and powerful closing spring provide valve closure in less than one second and reliable, long-life operation.

Series 8000 Valve's compact design simplifies piping design and minimizes space requirements.

The field-replaceable actuator provides easier maintenance and reduced downtime. The actuator can also be rotated around the valve body in 90° increments to fit your specific application requirements.

A unique stem seal design eliminates packing adjustments for reduced maintenance and minimized drag on closing.

The large top-mounted open-shut indicator is visible from all angles for easy proof of valve position. FM and CSA approvals for use as a fuel safety shut-off valve making easy integration with worldwide certifications.

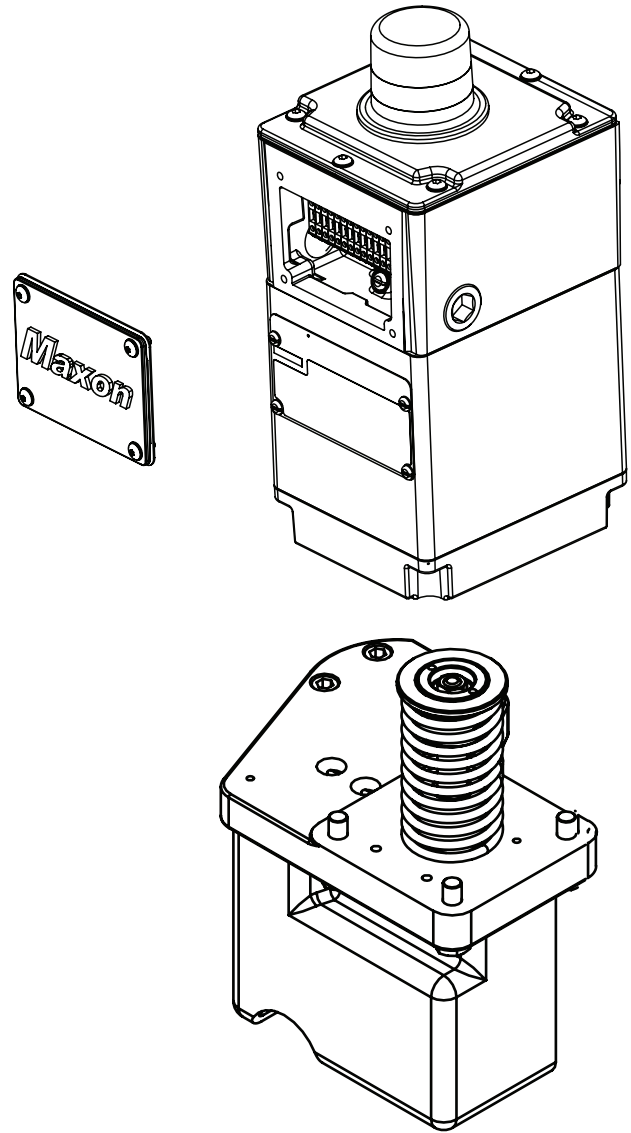

Switch Assemblies

- Provides positive valve position - open or closed
- Complies with "proof of closure" requirements
- Easily integrates with an analog control system, DCS or PLC

VOS2/VCS2 Switch Assemblies with Terminal Blocks and Leads Mounted

- Factory-mounted to terminal strip to shorten installation time
- Easy replacement (2 screws)
- Locating pins guarantee accurate mounting position
- No adjustment required

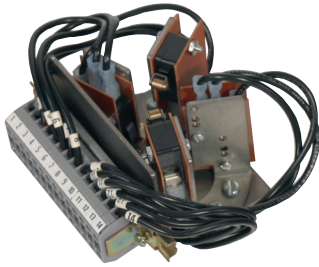

V7 Assembly for General Purpose and Intrinsically Safe Class I Div. 1 Areas and Zone 0 Areas

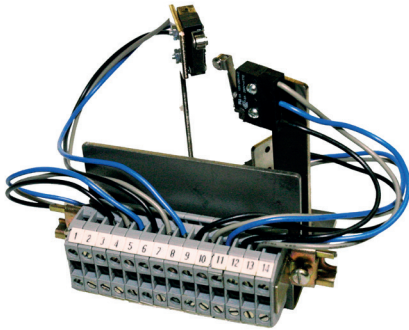

IP67 Switch Assembly for Non-Incendive Class I Div. 2 and Zone 2 Areas and Optional Class I Div. 1 Areas and Zone 0 Areas

Body and Trim Selections

Cast iron and carbon steel body assemblies feature metal-to-metal seating that meets FCI 70-2 control valve standard for Class VI seat leakage. Industrial-strength high alloy discs and hex nuts are available. Contact MAXON with your specific application details.

Valve bodies are available in your choice of threaded, flanged and socket-welded connections. Bodies are currently available in 3/8" (DN10) through 1-1/4" (DN32).

Normally-closed shut-off valves use instrument air to open quickly. Removal of electrical signal allows release of control air through solenoid and quick exhaust valve allowing the Series 8000 Valve to close in less than one second. Optional speed control set kit available for slower opening adjustment.

Series 8031, 8032 & 8033

require 30-100 psig instrument air















Series 8131, 8132 & 8133

require 30-100 psig instrument air



AGENCY APPROVALS AND CERTIFICATIONS

(Will vary with specific options selected)

	General Purpose Valves 8131, 8031 Series		Non-Incendive/Non-Sparking Valves 8131, 8031 Series		Intrinsically Safe Valves 8131, 8031 Series	
	Standards	Markings	Standards	Markings	Standards	Markings
FM Approvals	FM 7400		FM 3611 FM 3600 FM 3810 NEMA 250 IIEC 60529	Class I, Div 2, Groups ABCD, T4 Class II, Div 2, Groups FG, T4 Class III, Div 2, T4 	FM 3610 FM 3600 FM 3810 NEMA 250 IIEC 60529	Class I, Div 1, Groups ABCD, T5 Class II, Div 1, Groups EFG, T5 Class III, Div 1, T5 
CSA/SIRA-IECEx Certification	Not Applicable	None	IEC 60079-0 IEC 60079-15 IEC 60079-31	IECEx SIR 19.0017X Ex nA nC IIC T4 Gc (T5 w/ IS coil) Ex tc IIIC T135°C Dc -50°C ≤ Ta ≤ +60°C (+50 w/ IS coil)	IEC 60079-0 IEC 60079-11	IECEx SIR 19.0017X Ex ia IIC T5 Gb Ex tc IIIC T135°C Dc -50°C ≤ Ta ≤ +50°C
CSA International	CSA 6.5 - 2015		CSA C22.2: No. 213-M1987 No. 1010.1 CAN/CSA-E60079-0 CAN/CSA-E60079-15	Class I, Div 2, Groups ABCD, T4 Class II, Div 2, Groups FG, T4 Class III, Div 2, T4 Ex nA IIC T4 Ta=-50°C to +60°C (w/ std coil) Ex nA IIC T5 Ta=-50°C to +50°C (w/ IS coil) (Zone 2 approval)  03.1433937X	CSA C22.2: No. 157-M1992 No. 1010.1 CAN/CSA-E60079-0 CAN/CSA-E60079-11	Class I, Div 1, Groups ABCD, T5 Class II, Div 1, Groups EFG, T5 Class III, Div 1, T5 Ex ia IIC T5, -50°C < Ta < +50°C (Zone 0 Approval)  Ex ia 03.1433937X
United Kingdom Approvals (Hazardous Locations) ¹	Not Applicable	None	Not Applicable	None	BS EN 60079-0 BS EN 60079-11 BS EN 60529+A1 BS EN 13463-1 BS EN 13463-5	Sira 19ATEX2040X II 2GD Ex ia IIC T5 Gb Ex ia IIIC T100°C Db Ta = -50°C to +50°C IP65 
NCC/Inmetro	Not Applicable	None	ABNT NBR: IEC 60079-0 IEC 60079-15 IEC 60079-31	 Ex nA nC IIC T4 Gc -50°C ≤ Ta ≤ +60° Ex tc IIIC T135°C Dc IP65  Ex nA nC IIC T5 Gc -50°C ≤ Ta ≤ +50°C Ex tc IIIC T135°C Dc IP65	ABNT NBR: IEC 60079-0 IEC 60079-11 IEC 60079-31	 Ex ia IIC T5 Gb -50°C ≤ Ta ≤ +50°C Ex tc IIIC T135°C Dc IP65
KTL	Not Applicable	None	Announcement No. 2010-36 of Ministry of Employment and Labor	Ex nA nC IIC T4 (-50°C ≤ Ta ≤ +60°C) 	Announcement No. 2010-36 of Ministry of Employment and Labor	Ex ia IIC T5 (-50°C ≤ Ta ≤ +50°C) 
Chinese Approvals	None	None	GB 3836.1, GB 3836.8, GB 12476.1, GB 12476.5	Ex nA nC IIC T4 Gc (T5 w/ IS coil), -50°C < Ta < +60°C (+50°C w/ IS coil), Ex tD A22 IP65 T135°C 	GB 3836.1, GB 3836.4, GB 12476.1, GB 12476.5	Ex ia IIC T5 Gb, -50°C < Ta < +50°C, Ex tD A22 IP65 T135°C 
European Approvals ¹ (Hazardous Locations)	Not Applicable	None	Not Applicable	None	EN 60079-0 EN 60079-11 EN 60529+A1 EN 13463-1 EN 13463-5	Sira 19ATEX2040X II 2GD Ex ia IIC T5 Gb Ex ia IIIC T100°C Db Ta = -50°C to +50°C IP65 

¹ Product certified to meet the following: ATEX Regulation (2014/34/EU)

Valve cycle requirements

This is based on the standards that MAXON valves are approved to and the corresponding minimum number of cycles to be completed without failure as shown in the chart below.

	CSA (CSA 6.5)	FM (FM 7400)
Automatic - Normally-Closed Series 8031, 8131, 8032, 8132, 8033, 8133	100,000	20,000

VALVE MODEL NUMBER DESCRIPTION

Every MAXON Series 8000 Valve can be accurately identified by the model number shown on the valve nameplate. The example below shows a typical Series 8000 Valve model number, along with the available choices for each item represented in the model number. The first five choices determine the valve's configured item number. Valve body and actuator options are identified by the next eight characters in the model number.

Configured Item Number					Valve Body					Actuator					
Valve Size	Flow Capacity	Pressure Rating	Normal Position	Area Classification	Body Connection	Body Seals & Stem Packing	Body Material	Internal Trim Package	Primary Voltage	Switch Option	Enclosure Rating	Instruction Language	Visual Indication		
038	S	81	3	1	-	A	B	1	D	-	B	1	A	0	1

Valve Size

038 – 3/8" (DN 10)
 050 – 1/2" (DN 15)
 075 – 3/4" (DN 20)
 100 – 1" (DN 25)
 125 – 1-1/4" (DN 32)

Flow Capacity

H – High
 S – Standard

Operating Pressure Rating

80 – Pneumatic Standard Pressure
 81 – Pneumatic High Pressure

Normal Position

3 – Normally-Closed Liquid Shut-Off Valve

Area Classification

1 – General Purpose
 2 – Non-incendive, Class I, II and III Division 2
 3 – Intrinsically Safe, Class I, II and III Division 1 (and ATEX Zone 1/21) ¹
 4 – Valve Body Only

¹ 122°F maximum ambient temperature limit

² Not a selection on Body Only

Body Connection

A – NPT
 E – Socket Welded Nipple
 F – Socket Welded Nipple w/Class 150 (PN20) Flanges
 G – Socket Welded Nipple w/Class 300 (PN50) Flanges
 H – EN 1092-1 PN16 Flanged
 I – Socket Welded Nipple w/Class 600 (PN110) Flanges
 J – Butt-Welded Nipple X – Special
 U – Actuator Only

Body Seals & Stem Packing

A – Buna-N w/PTFE
 B – Viton™ w/PTFE
 C – Ethylene-Propylene w/PTFE
 D – Kalrez® w/Grafoil®
 X – Special
 U – Actuator Only

Body Material

1 – Cast Iron
 2 – Carbon Steel
 X – Special
 U – Actuator Only

Internal Trim Package

B – Ductile
 D – Stellite
 P – PEEK
 X – Special
 U – Actuator Only

Primary Voltage²

A – 120VAC 50Hz
 B – 120VAC 60Hz
 D – 240VAC 50Hz
 E – 240VAC 60Hz
 G – 24VDC
 H – 24VDC IS ¹
 J – 24VDC IS-ATEX ¹
 X – Special
 Z – None (customer-supplied, external mount)

Switch Option²

0 – None
 1 – VOS1/VCS1 - V7
 2 – VOS2/VCS2 - V7
 3 – VOS1/VCS1 - IP67
 4 – VOS2/VCS2 - IP67
 X – Special

Enclosure Rating²

A – NEMA 4, IP65
 B – NEMA 4X, IP65
 X – Special

Instruction Language²

0 – English
 1 – French
 3 – German
 4 – Portuguese
 5 – Spanish
 6 – Chinese

Visual Indication²

1 – Red-closed/green-open
 2 – Red-open/green closed
 3 – Yellow-open/black-closed

VALVE BODY ASSEMBLY OPTIONS & SPECIFICATIONS

Series 8000 normally-closed liquid shut-off valves						
Nominal pipe size	Flow capacity	Actuator pressure class	Body connections available	Body material	Trim package options	Cv rating
3/8" (DN10)	Standard	High	A,C	1	D	3.4
1/2" (DN15)	Standard	High	A,C	1,2	D, P	3.4
			E,F,G,I,J	2		
3/4" (DN20)	Standard	High	A,C	1,2	D, P	9.6
			E,F,G,I,J	2		
1" (DN25)	Standard	Standard	A,C	1,2	B,D,P	12
			E,F,G,I,J	2		
		High	A,C	1,2		
			E,F,G,I,J	2		
1-1/4" (DN32)	Standard	Standard	A,C	1,2	B,D,P	17
			E,F,G,I,J	2		
		High	A,C	1,2		
			E,F,G,I,J	2		
	High Cap.	Standard	A,C,E,F,G,I,J	2	D	45
		High	A,C,E,F,G,I,J	2		

Body Connections:

A - NPT

C - ISO 7-1 Threaded

E - Socket Welded Nipple

F - Socket Welded Nipple w/Class 150 (PN20) Flange

G - Socket Welded Nipple w/Class 300 (PN50) Flange

H - EN 1092-1 (PN16) Flanged

I - Socket Welded Nipple w/ Class 600 (PN110) Flange

J - Butt-Welded Nipple

X - Special

Body Material:

1 - Cast Iron

2 - Cast Steel

Trim Packag Options and Typical Material:

B - Ductile

D - Stellite

P - PEEK

Body Seals:

Standard elastomers are Buna-N, Viton™, Ethylene-Propylene and Kalrez®.

Standard packings are PTFE and Grafoil®.

Maximum operating pressure ratings

Series 8000 normally-closed liquid shut-off valves							
Nominal pipe size	Flow capacity	Actuator pressure class	Cv rating	Maximum MOPD Rating (psig) Refer to pressure/temperature graph below for ratings			
				Fluid group (see below for details)			
				Group 1	Group 2	Group 3	Group 4
3/8" (DN10)	Standard	High	3.4	400	400	300	250
1/2" (DN15)	Standard	High	3.4	740	740	300	250
3/4" (DN20)	Standard	High	9.6	740	740	300	250
1" (DN25)	Standard	Standard	12	400	400	300	235
		High		740	740	300	250
1-1/4" (DN32)	Standard	Standard	17	360	360	280	215
		High		740	740	300	250
	High	Standard	45	190	180	140	110
		High		385	375	300	235

Group 1 fluids include:

JP4, Kerosene, No. 1 fuel oil, No. 2 fuel oil, and Ammonia

Group 2 fluids include:

No. 4 fuel oil, No. 5 fuel oil, and No.6 fuel oil

Group 3 fluids include:

Liquid Ethanol, Liquid Methanol, No. 6 fuel oil (heavy), Liquid Butane and Liquid Propane

Group 4 fluids include:

Residual fuel oil and Steam

NOTE: MOPD ratings are based on a viscosity of 150 SSU or less. Higher viscosities may result in further reductions. Contact MAXON for details.

Pressure/Temperature Chart

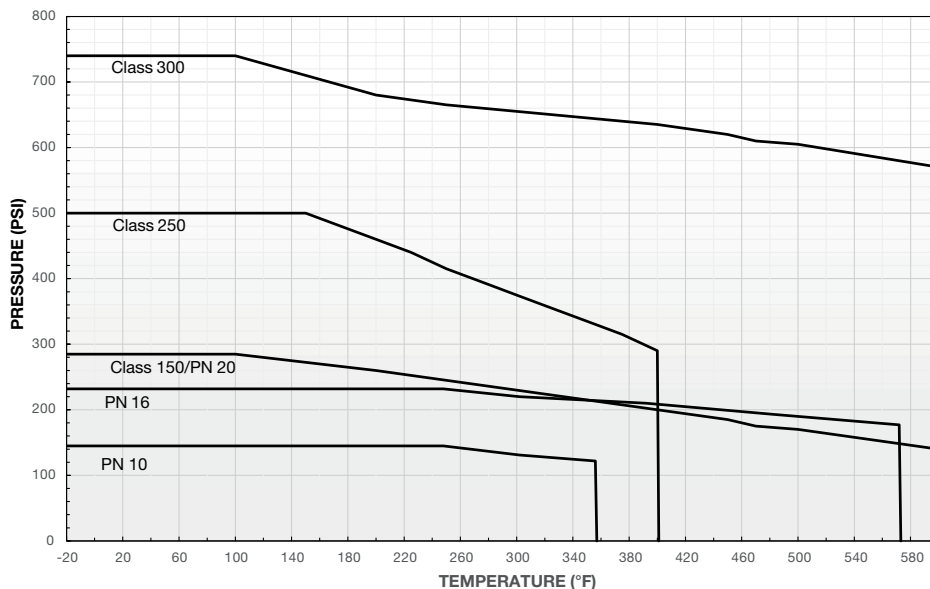

NOTE: Ratings are in accordance with ASME B16.4, ASME B16.5, EN 1092-1 or ISO 7005.

Class 250 applies to: connection choice A

PN20 applies to: connection choice C

Class 150 applies to: connection choice F

Class 300 applies to: connection choices A, B, E, G, I, and J

PN16 applies to: connection choices C, E, H, and J

NOTE: EN 1092-1 and ISO 7005 allow PN16 products to be used in PN10 systems. The MOPD ratings are reduced in those instances.

Valve Body Capacities with #2 Oil

To select a valve for your application, use either Cv factor calculations, or this graph showing approximate pressure drop at various flows of #2 oil.

Typically, pressure drop for fuel flows should not exceed 10% of inlet pressure.

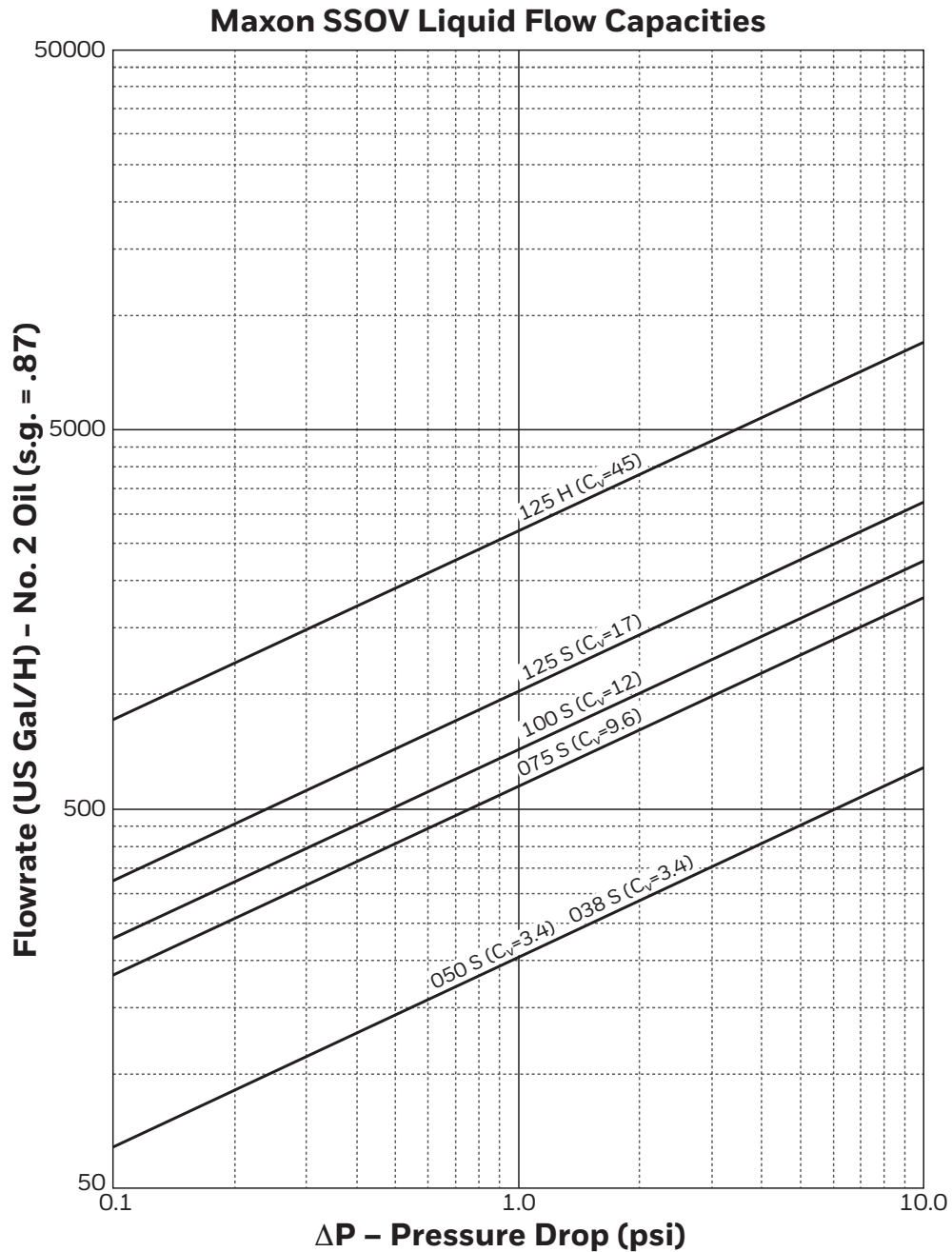

For preheated #5 or #6 oil, multiply the required flow rate in GPH by the factor given in the table at right, then select a valve based upon that equivalent flow of #2 oil and the allowable drop.

Oil Grade	#5		#6				
	°F @ Inlet	125	160	120	140	180	210
Factor	1.43	1.11	2.86	2.00	1.25	1.11	1.05

For example: To size for 5 PSIG drop with a 3500 GPH flow of #6 oil preheated to 140°F, the multiplier is 2. Equivalent flow of #2 oil is then 3500 x 2, or 7000 GPH. Chart shows that a 5 PSIG drop will require use of a valve body having a Cv factor of at least 45.

Media compatibility and valve approval certifications								
Media	Media Code	Suggested Material Options			MOPD Rating ^{4, 5}	Agency Approvals and Certifications		
		Body Seals & Stem packing	Body Material	Internal Trim		FM	CSA ⁷	ATEX
Ammonia (anhydrous)	AMMA	C,D	1,2	D	Std.	X	X	X
Ethanol (liquid)	ETHL	A,C,D	2	D,P	Note ²	X	X	X
JP4	JP4	A,B,D	1,2	B,D	Std.	X	X	X
Kerosene	KERO	A,B,D	1,2	B,D	Std.	X	X	X
Methanol (liquid)	METHL	A,C,D	1,2	B,D,P	Note ²	X	X	X
No. 1 Fuel Oil	NO1OIL	A,B,D	1,2	B,D	Std.	X	X	X
No. 2 Fuel Oil	NO2OIL	A,B,D	1,2	B,D	Std.	X	X	X
No. 4 Fuel Oil (125 SSU max) ⁶	NO4OIL	A,B,D	1,2	B,D	Note ¹	X	X	X
No. 5 Fuel Oil (900 SSU max) ⁶	NO5OIL	A,B,D	1,2	B,D	Note ¹	X	X	X
No. 6 Fuel Oil (2500 SSU max) ⁶	NO6OIL	A,B,D	1,2	B,D	Note ¹	X	X	X
No. 6 Fuel Oil (7000 SSU max) ⁶	NO6OILH	A,B,D	1,2	B,D Note ²	X	X	X	
Residual oil (15000 SSU max) ⁶	RESID	A,B,D	1,2	B,D	Note ³	X	X	X
Butane (liquid)	BUTL	A,D	1,2	B,D,P	Note ²	X	X	X
Propane (liquid)	PROPL	A,D	1,2	B,D,P	Note ²	X	X	X
Steam	STEAM	D	1,2	B,D,P	Note ³	X	X	X

¹ Group 2 fluid MOPD ratings are typically 5% lower than standard MOPD ratings (refer to chart on page 8 (Maximum operating pressure ratings))

² Group 3 fluid MOPD ratings are typically 30% lower than standard MOPD ratings (refer to chart on page 8 (Maximum operating pressure ratings))

³ Group 4 fluid MOPD ratings are typically 40% lower than standard MOPD ratings (refer to chart on page 8 (Maximum operating pressure ratings))

⁴ MOPD ratings for fuel oils are based on a viscosity of 150 SSU or less. Higher viscosities may result in further reductions to MOPD ratings. Contact MAXON for details.

⁵ For elevated fluid temperatures, the MOPD is to be reduced in accordance to the applicable piping standard(s).

⁶ Indicated SSU maximum is based on 100°F standard.

⁷ CSA certification does NOT apply if the body connections are either ISO threaded or EN1092 flanged.

Body Seals & Packing:

A - Buna-N w/ PTFE

B - Viton™ w/ PTFE

C - Ethylene-Polypropylene w/ PTFE

D - Kalrez® w/ Grafoil®

Body Material:

1 - Cast Iron

2 - Cast Steel

Internal Trim Package

B - Ductile

D - Stellite

P - PEEK

Minimum required cylinder pressures

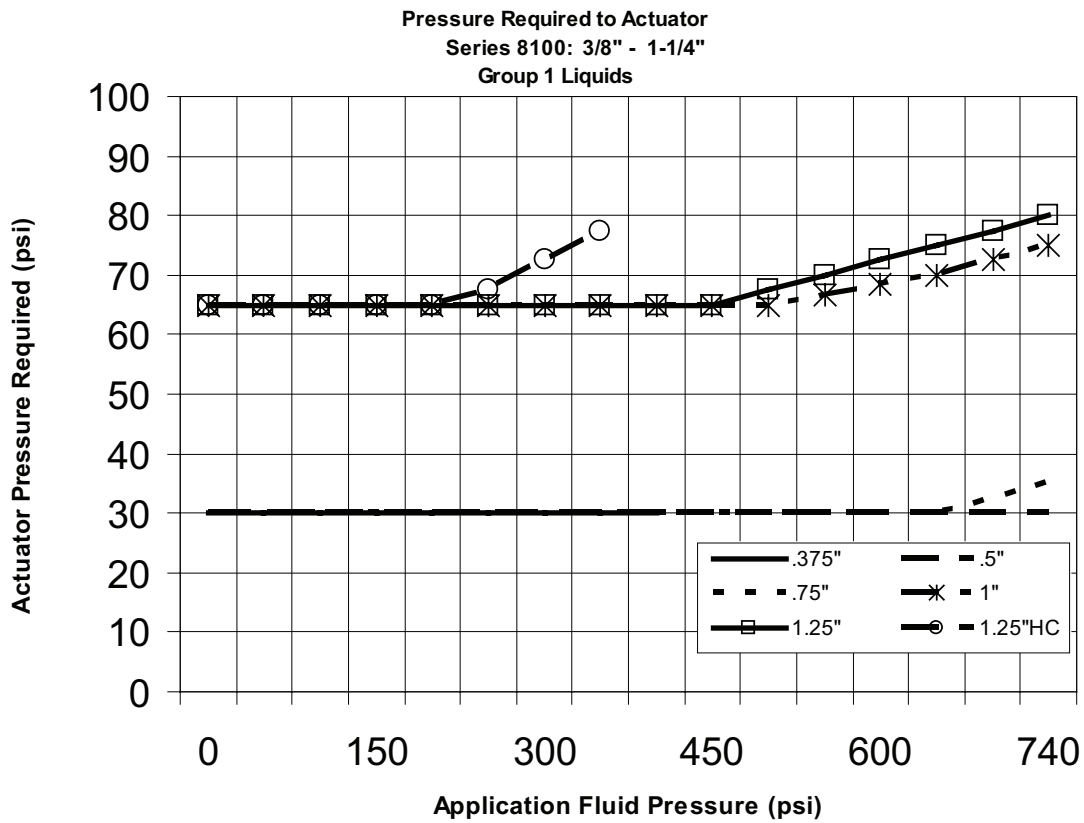
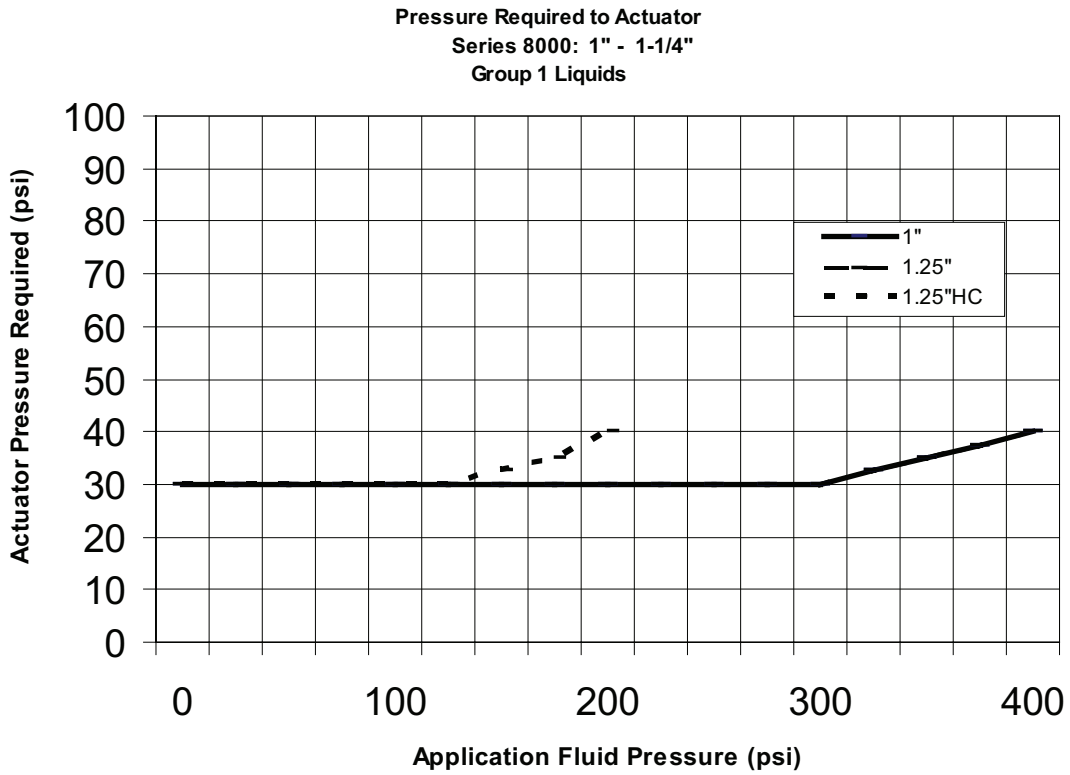

Group 1 fluids include:
JP4, Kerosene, No. 1 Fuel oil, No. 2 Fuel oil, and Ammonia

Pressure Required to Actuator
 Series 8000: 1" - 1-1/4"
 Group 2 Liquids

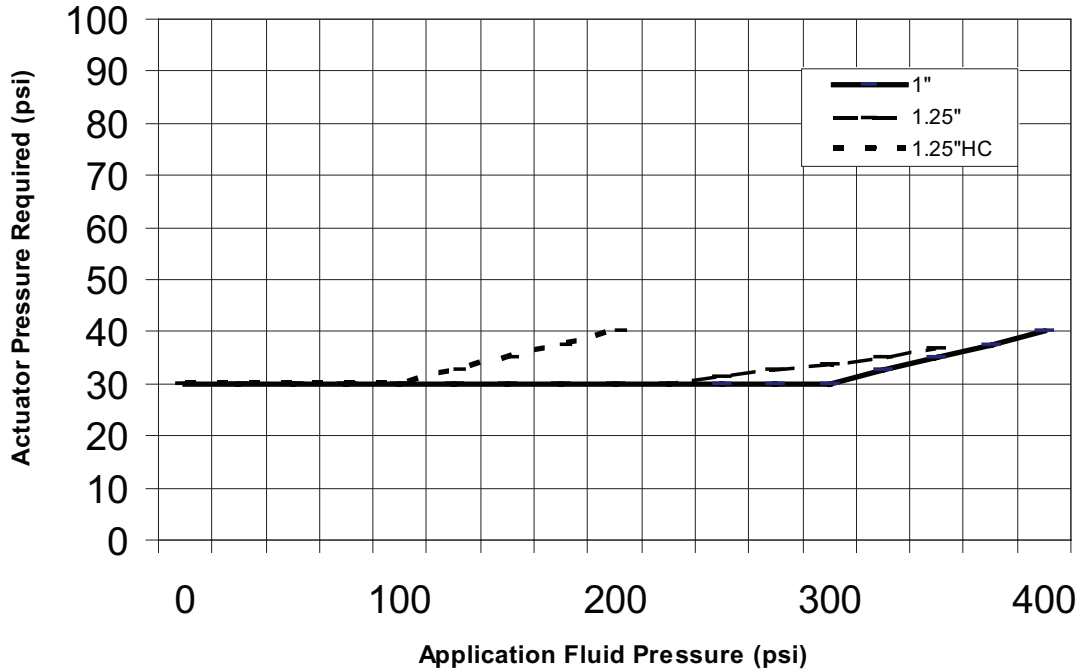

Pressure Required to Actuator
 Series 8100: 3/8" - 1-1/4"
 Group 2 Liquids

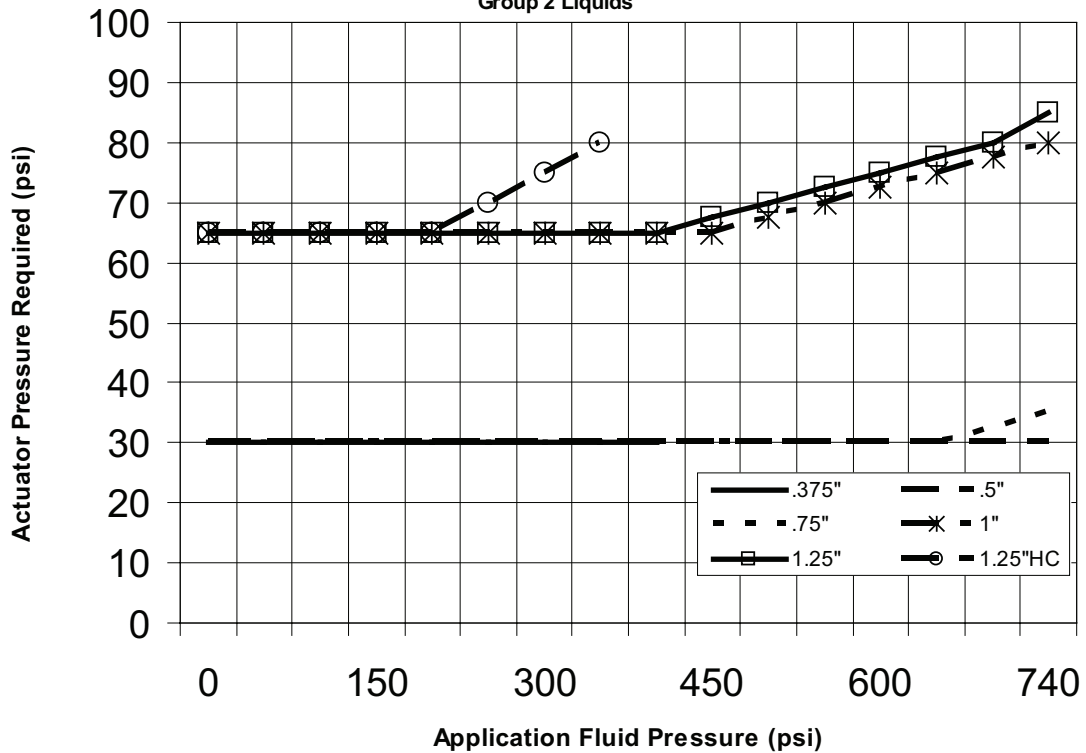

Group 2 fluids include:
 No. 4 fuel oil, No. 5 fuel oil, and No.6 fuel oil

Pressure Required to Actuator
 Series 8000: 1" - 1-1/4"
 Group 3 Liquids

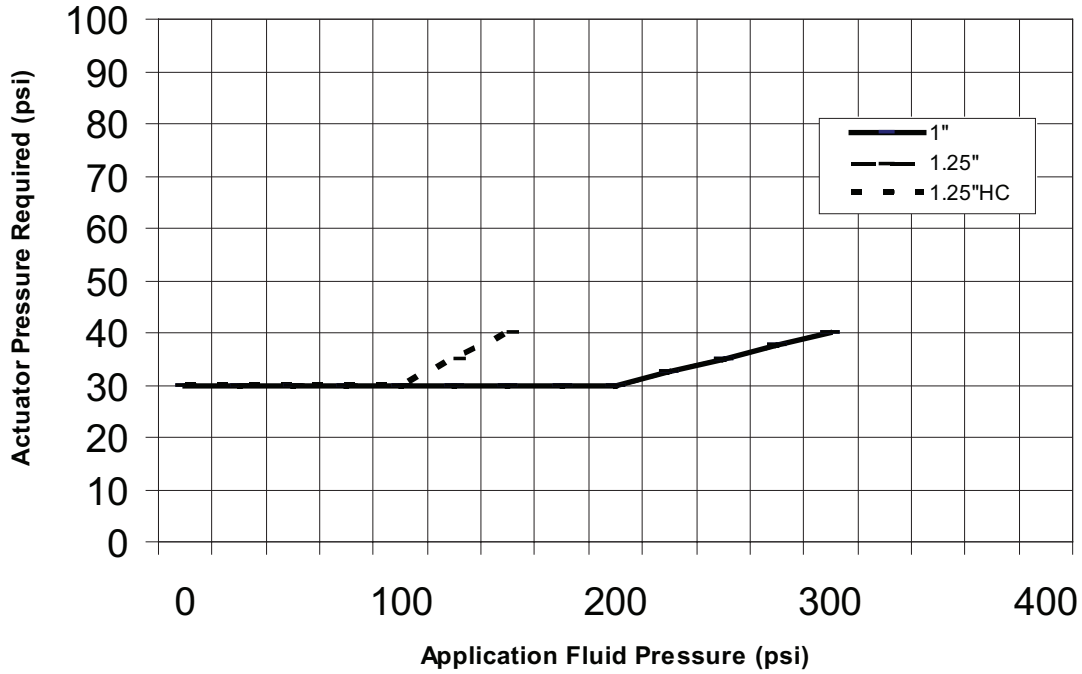

Pressure Required to Actuator
 Series 8100: 3/8" - 1-1/4"
 Group 3 Liquids

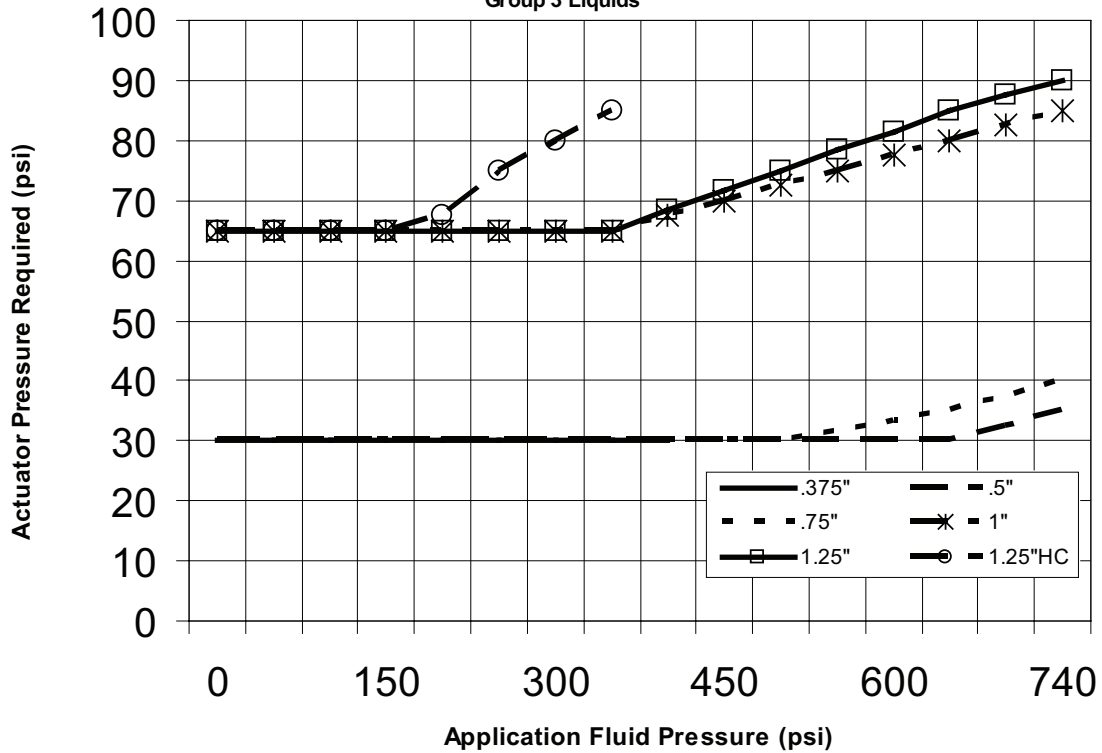

Group 3 fluids include:
 Liquid Ethanol, Liquid Methanol, No. 6 Fuel oil (heavy),
 Liquid Butane and Liquid Propane

**Pressure Required to Actuator
Series 8000: 1" - 1-1/4"
Group 4 Liquids**

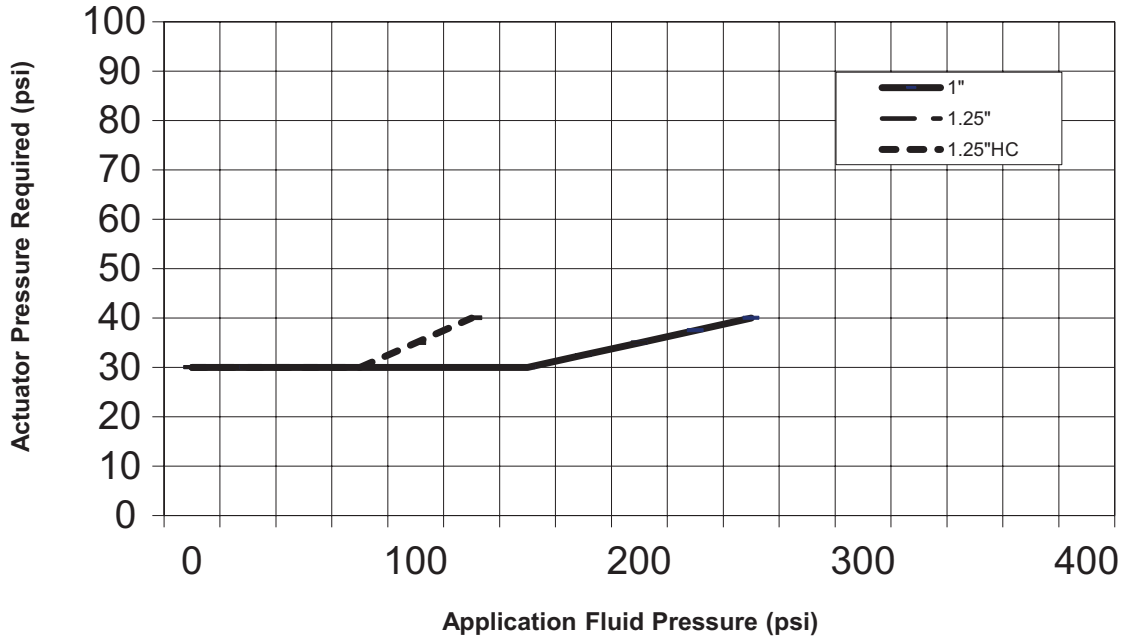

**Pressure Required to Actuator
Series 8100: 3/8" - 1-1/4"
Group 4 Liquids**

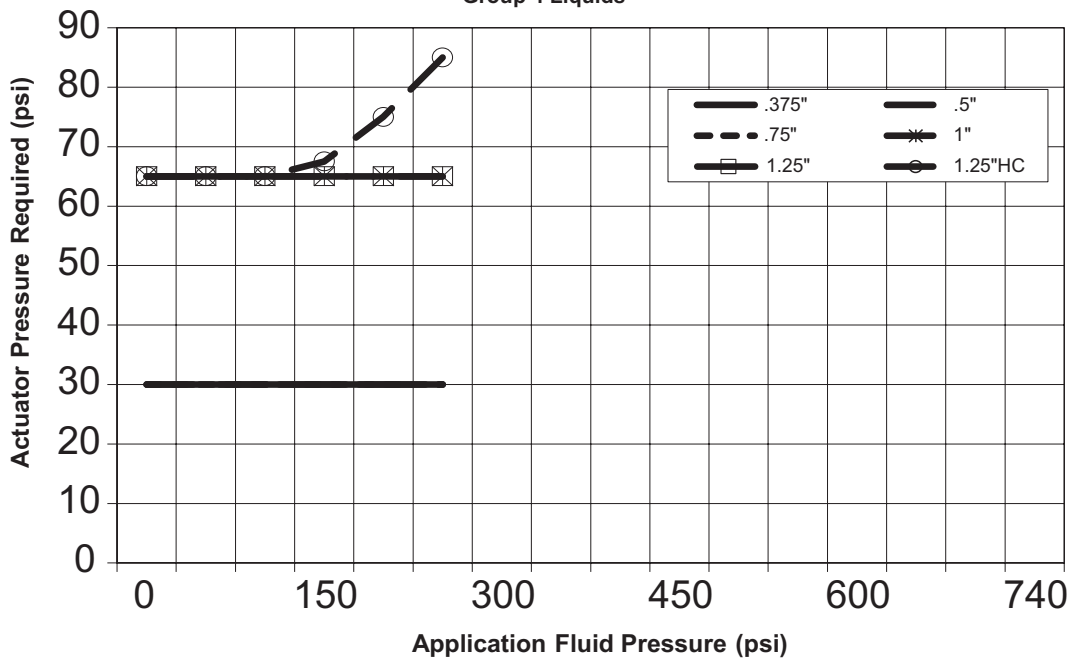

Group 4 fluids include:
Residual fuel oil and Steam

Accessories

Speed Control Set Kits

Manually adjustable valve restricts flow to the actuator inlet and so reduces opening speed of the normally closed shut-off valve.

- Available in carbon steel and stainless steel construction
- 90° mating elbow provided for easy assembly
- Tamper-proof set screw prevents accidental misadjustment

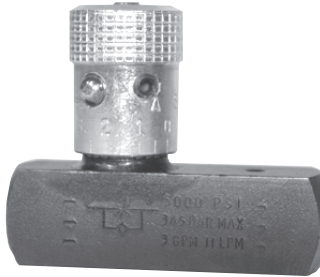

Kit No. 1067124
Carbon Steel construction



Kit No. 1067125
Stainless Steel construction

Intrinsic Safety Interfaces

Approved units interposed between the hazardous and safe area circuits limit parameters such as voltage, current or power.

- Suitable for use in Class I, Div. 2 areas
- DIN rail mounted
- Complements intrinsically safe Series 8000 Valves

Engineering recommendations for barriers and isolator option				
Manufacturer	IS interface type	Model no.	Application	MAXON no.
MTL	Zener Diode ¹	MTL 7728+	Solenoid	1067656
		MTL 7787+	Switch ²	1067655
	Isolator ³	MTL 5025	Solenoid	1067660
		MTL 5018	Switch ⁴	1067659

¹ Circuit must be isolated from earth in hazardous area

² Two barriers required for VOS1 / VCS1

³ Circuit may be earthed at one point in hazardous area

⁴ One barrier required for VOS1 / VCS1

Component identification

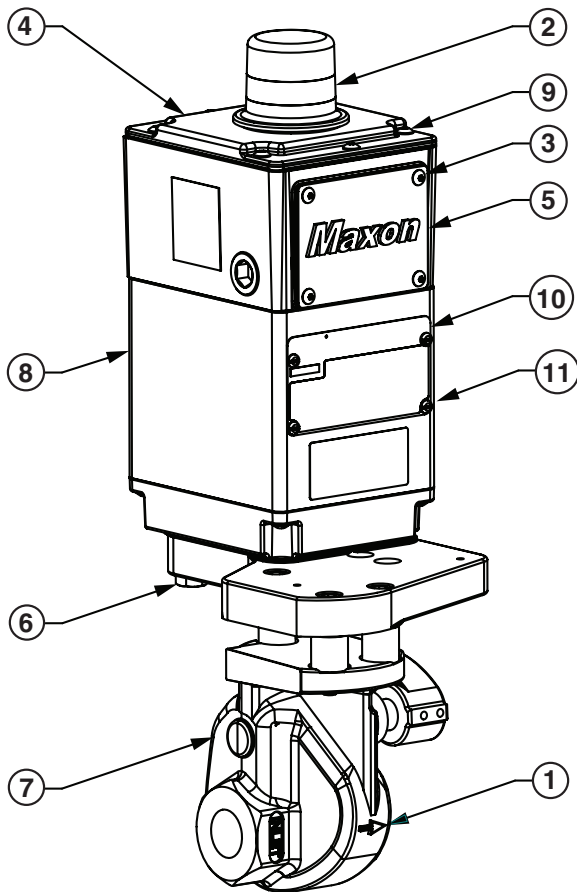

1)	Flow arrow
2)	Visual indication
3)	Terminal block cover screws, M5 x 12
4)	Switch access cover
5)	Terminal block cover
6)	Actuator bolts, M10 x 50 - M10 x 62 or M10 x 35
7)	Valve body
8)	Actuator
9)	Switch access cover screws, M6 x 20
10)	Nameplate
11)	Nameplate screws, M4 x 6

Installation

1. A filter or strainer of 40 mesh (0.6 mm maximum) or greater is recommended in the fuel piping to protect the downstream safety shut-off valves.
2. Properly support and pipe the valve in the direction of the flow arrow on the valve body. Valve seats are directional. Sealing will be maintained at full rated pressures in one direction only. Sealing will be provided in reverse flow only at reduced pressures.
3. Mount valve so that open/shut indicator will not face downward.
4. Series 8000 Valves require clean, dry compressed air or gas piped to the inlet of the actuator. Guidelines for various actuating gases:
 - A. Compressed Air
 1. The vent, located on the underside of the base plate, should be protected from blockage.
 2. Although MAXON Series 8000 Valves do not require lubrication, they do contain Buna-N (-40°F) seals in the actuator sub-assembly. Compressed air supply must not contain any lubricant that is not compatible with Buna-N elastomers.
 - B. Natural gas and other fuel gases can be used to actuate the Series 8000 Valve when the appropriate considerations are taken into account.
 1. Apply only the intrinsically safe Series 8000 Valve for the application. The general purpose and non-incendive options are not suitable for fuel gas activation.
 2. The activating fuel gas must be clean and free of moisture. The Series 8000 actuator contains Buna-N elastomers and brass components that will come in contact with the activating gas. The quality of the gas must not contain any constituents that are not compatible with Buna-N or brass.
 3. The exhaust gas must be vented to the atmosphere in a safe manner by piping from the filtered vent, located on the underside of the actuator's base. A 1/8" NPT female connection in the base plate allows for proper piping.
 4. The use of fuel gases for actuation is not permitted in EC areas due to ATEX Zone 2 restrictions.
 5. Actuators for fuel gas activation are only rated from -40°F to 140°F
5. In some instances, it may be desired to utilize a slow opening feature for either application or code-related reasons. If a slow opening feature is required for nor-

mally closed shut-off valves, use MAXON's optional speed control set kit.

6. Wire the valve in accordance with all applicable local and national codes and standards. In U.S. and Canada, wiring must conform to the NEC ANSI/NFPA 70 and/or CSA C22.1, Part 1.
 - A. Supply voltages must agree with valve's nameplate voltage within -15%/+10% for proper operation. For electrical wiring schematic, see instructions or sample affixed inside valve terminal block cover.
 - B. Grounding is achieved with a grounding screw, which is located in the top assembly.
 - C. Customer connections are provided via terminal block located in the top assembly.
 - D. Main power wiring (120 VAC or 240 VAC) must be segregated from lower voltage 24 VDC signal wiring, when both are required.

WARNING: For Division 2 installations using the intrinsically safe solenoid, the power source is not to exceed 28VDC with a minimum series resistance of 300 ohms.
7. Maintain integrity of the Series 8000 actuator enclosure by using the appropriate electrical connectors for the (2) 3/4" NPT conduit threaded connections. The Series 8000 electrical enclosure is NEMA 4 and IP65 rated with an option for NEMA 4X.
8. All access cover plate screws should be tightened using an alternate cross-corner tightening pattern to the values shown in Table 1 below.

Table 1 - Torque Specifications

Item Number	Description	Torque
3	Terminal Block Cover Screws, M5 x 12	20 in-lbs
9	Switch Access Cover Screws, M6 x 20	20 in-lbs
6	Actuator Bolts, M10 x 50 - M10 x 62	13 ft-lbs
6	Actuator Bolts, M10 x 35	13 ft-lbs
11	Nameplate Screws, M4 x 6	10 in-lbs

9. Verify proper installation and operation by electrically actuating the valve for 10-15 cycles prior to the first introduction of liquid.
10. When customer-supplied, externally mounted solenoids are used, the component must be rated for the Class and Division of the hazardous area. MAXON 8032 and 8132 valve will only carry FM Approval to FM 3611, 3600 and 3810 standards. MAXON 8033 and 8133 valves will only carry FM Approval to FM 3610, 3600 and 3810 standards.

Operating characteristics

- Opening time varies per valve size, 3 seconds or less for largest size. For slower opening, a speed control set can be supplied by MAXON.
- Closing time is less than 1 second.
- Type of medium 4,5

Media compatibility and valve approval certifications								
Media	Media Code	Suggested Material Options			MOPD Rating ^{4 5}	Agency Approvals and Certifications		
		Body Seals & Stem packing	Body Material	Internal Trim		FM	CSA ⁷	ATEX
Ammonia (anhydrous)	AMMA	C,D	1,2	D	Std.	X	X	X
Ethanol (liquid)	ETHL	A,C,D	2	D,P	Note ²	X	X	X
JP4	JP4	A,B,D	1,2	B,D	Std.	X	X	X
Kerosene	KERO	A,B,D	1,2	B,D	Std.	X	X	X
Methanol (liquid)	METHL	A,C,D	1,2	B,D,P	Note ²	X	X	X
No. 1 Fuel Oil	NO1OIL	A,B,D	1,2	B,D	Std.	X	X	X
No. 2 Fuel Oil	NO2OIL	A,B,D	1,2	B,D	Std.	X	X	X
No. 4 Fuel Oil (125 SSU max) ⁶	NO4OIL	A,B,D	1,2	B,D	Note ¹	X	X	X
No. 5 Fuel Oil (900 SSU max) ⁶	NO5OIL	A,B,D	1,2	B,D	Note ¹	X	X	X
No. 6 Fuel Oil (2500 SSU max) ⁶	NO6OIL	A,B,D	1,2	B,D	Note ¹	X	X	X
No. 6 Fuel Oil (7000 SSU max) ⁶	NO6OILH	A,B,D	1,2	B,D	Note ²	X	X	X
Residual oil (15000 SSU max) ⁶	RESID	A,B,D	1,2	B,D	Note ³	X	X	X
Butane (liquid)	BUTL	A,D	2	B,D,P	Note ²	X	X	X
Propane (liquid)	PROPL	A,D	2	B,D,P	Note ²	X	X	X
Steam	STEAM	D	1,2	B,D,P	Note ³	X	X	X

¹ Group 2 fluid MOPD ratings are typically 5% lower than standard MOPD ratings (refer to chart on page 9 (Maximum operating pressure ratings))

² Group 3 fluid MOPD ratings are typically 30% lower than standard MOPD ratings (refer to chart on page 9 (Maximum operating pressure ratings))

³ Group 4 fluid MOPD ratings are typically 40% lower than standard MOPD ratings (refer to chart on page 9 (Maximum operating pressure ratings))

⁴ MOPD ratings for fuel oils are based on a viscosity of 150 SSU or less. Higher viscosities may result in further reductions to MOPD ratings. Contact MAXON for details.

⁵ For elevated fluid temperatures, the MOPD is to be reduced in accordance to the applicable piping standard(s).

⁶ Indicated SSU maximum is based on 100°F standard.

⁷ CSA certification does NOT apply if the body connections are either ISO threaded or EN1092 flanged.

Body Seals & Packing:

- A - Buna-N w/ PTFE
- B - Viton™ w/ PTFE
- C - Ethylene-Polypropylene w/ PTFE
- D - Kalrez® w/ Grafoil®

Body Material:

- 1 - Cast Iron
- 2 - Cast Steel

Internal Trim Package

- B - Ductile
- D - Stellite
- P - PEEK

Auxiliary Features

- Non-adjustable Proof of Closure Switch(es) with valve seal over travel interlock.
- Auxiliary switch for indication of full travel (open for normally closed valves).

Operating Environment

- Fluid temperature range of -40°F to 550°F .
- Actuators are rated for NEMA 4, IP65 or optional NEMA 4X, IP65.
- Ambient temperature range of -40°F to 140°F for the 8031 and 8131 General Purpose and 8032 and 8132 Non-Incendive series valves.
- Ambient temperature range of -40°F to 122°F for 8033 and 8133 Intrinsically Safe series valves.

Electrical Data

Normally-Closed Shut-Off Valves

General Purpose Normally-Closed Valves

Series 8031 & Series 8131

Switches: V7

Solenoid Valve: Standard

24 VDC, 4.8W,

120VAC, 50/60 Hz, 11/9.4 VA Peak, 8.5/6.9 VA Holding,

240VAC, 50/60 Hz, 11/9.4 VA Peak, 8.5/6.9 VA Holding,

See catalog or inside valve cover for wiring schematic.

Class I, Div. 2 Hazardous Location Normally-Closed Valves

Series 8032 & Series 8132

Switches: IP67

Solenoid Valve: Standard

24 VDC, 4.8W,

120VAC, 50/60 Hz, 11/9.4 VA Peak, 8.5/6.9 VA Holding,

240VAC, 50/60 Hz, 11/9.4 VA Peak, 8.5/6.9 VA Holding,

24VDC IS, 0.09W

Class I, Div. 1 and ATEX Zone 1 Intrinsically Safe Hazardous Location Normally-Closed Valves

Series 8033 & Series 8133

Switches: V7 with optional IP67

Solenoid Valve: Intrinsically Safe

NOTES:

- 1) The Intrinsic Safety Entity concept allows the interconnection of two FM approved (CSA certified when installed in Canada) intrinsically safe devices with entity parameters not specifically examined in combination as a system when:

$$V_{oc} \text{ or } U_o \text{ or } V_t \leq V_{max}, I_{sc} \text{ or } I_o \text{ or } I_t \leq I_{max}, C_a \text{ or } C_o \geq C_i + C_{cable}, L_a \text{ or } L_o \geq L_i + L_{cable}, \text{ and for FM only: } P_o \leq P_i.$$

- 2) Dust-tight conduit seal must be used when installed in Class II and Class III environments.
- 3) Control equipment connected to the Associated Apparatus must not use or generate more than 250 Vrms or Vdc.
- 4) Installation in the U.S. should be in accordance with ANSI/ISA RP12.06.01 "Installation of Intrinsically Safe Systems for Hazardous (Classified) Locations" and the National Electric Code® (ANSI/NFPA 70) Sections 504 and 505.
- 5) Installation in Canada should be in accordance with the Canadian Electrical Code, CSA C22.1, Part 1, Appendix F.

- 6) Installation in the European Union should be in accordance to Regulation 2014/34/EU (ATEX). In case the valve and/or its switches have a safety function, the use of fail safe equipment is required.
- 7) The configuration of associated Apparatus must be FM approved (CSA certified when in Canada) under Entity Concept.
- 8) Associated Apparatus manufacturer's installation drawing must be followed when installing this equipment.
- 9) No revision to drawing without prior authorization from FM Approval and CSA International.

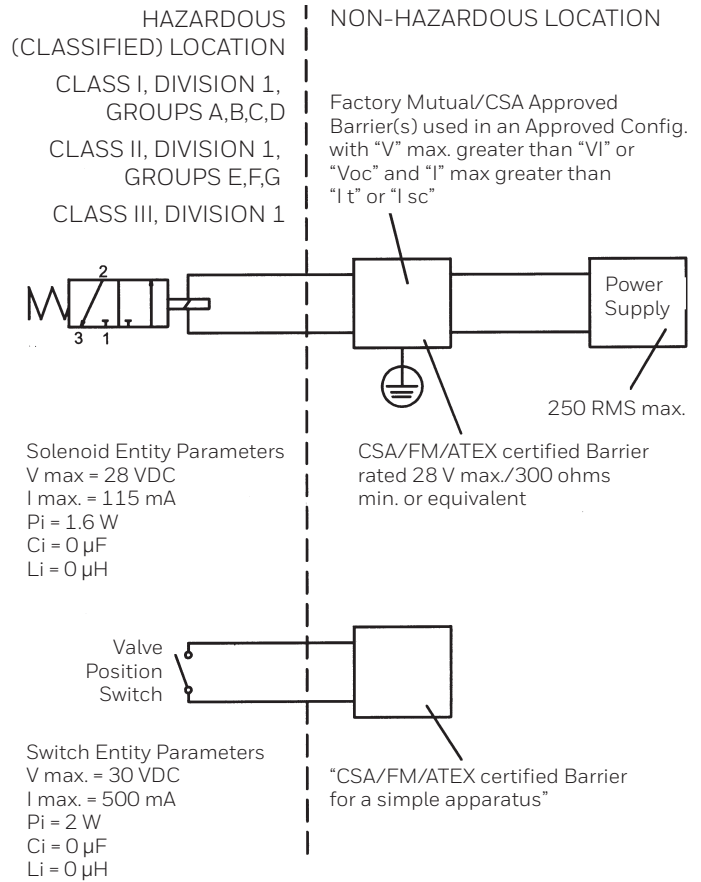

Class I, Div. 1 and ATEX Zone 1 Intrinsically Safe Hazardous Location Normally-Closed Valves

Series 8033 & Series 8133

Switches: V7 with optional IP67

Solenoid Valve: Customer-supplied, externally mounted

NOTES:

- 1) The Intrinsic Safety Entity concept allows the interconnection of two FM approved (CSA Certified when installed in Canada) Intrinsically safe devices with entity parameters not specifically examined in combination as a system when:
 V_{oc} or U_o or $V_t \leq V_{max}$, I_{sc} or I_o or $I_t \leq I_{max}$, C_a or $C_o \geq C_i + C_{cable}$, L_a or $L_o \geq L_i + L_{cable}$, and for FM only: $P_o \leq P_i$.
- 2) Dust-tight conduit seal must be used when installed in Class II and Class III environments.
- 3) Control equipment connected to the Associated Apparatus must not use or generate more than the maximum permissible safe area voltage (U_m) for the barrier.
- 4) Installation in the U.S. should be in accordance with ANSI/ISA RP12.06.01 "Installation of Intrinsically Safe Systems for Hazardous (Classified) Locations" and the National Electric Code® (ANSI/ NFPA 70) Sections 504 and 505.
- 5) Installation in Canada should be in accordance with the Canadian Electrical Code, CSA C22.1, Part 1, Appendix F.
- 6) Installation in the European Union should be in accordance to Regulation 2014/34/EU (ATEX).
- 7) The configuration of associated Apparatus must be FM Approved (CSA Certified when in Canada) under Entity Concept.
- 8) Associated Apparatus manufacturer's installation drawing must be followed when installing this equipment.
- 9) No revision to drawing without prior authorization from FM Approval and CSA International.

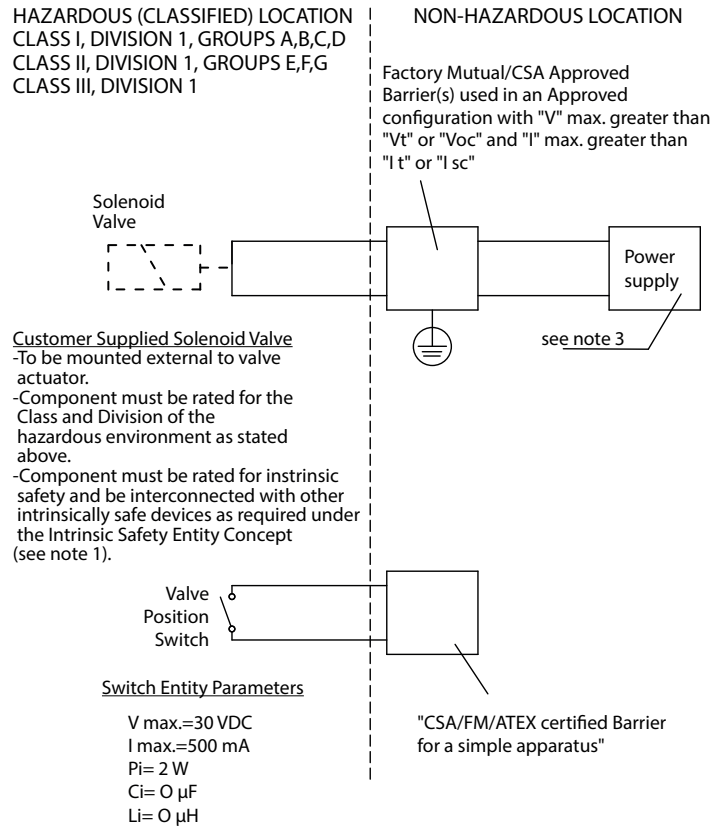

Actuator Assembly Rotation/Replacement



MAXON Series 8000 Valves should be ordered in a configuration compatible with planned piping. If valve orientation is not correct, the actuator assembly can be rotated in 90° increments around the valve body center line axis using the procedure below. This procedure should also be followed for field replacement of the actuator.

- **Shut off all electrical power** and close off upstream manual cock.
- **Remove terminal block access cover plate {5}** and disconnect power lead wires. Caution: Label all wires prior to disconnection when servicing valve. Wiring errors can cause improper and dangerous operation.
- **Remove conduit and electrical leads.**
- Remove all pneumatic lines.
- Remove front lower cover from adapter base assembly.
- **Unscrew the actuator/adapter bolts {6}** screwed up from the bottom. These bolts secure the valve actuator {8} to the adapter base {7}.
- **Gently lift the actuator {8} off adapter base assembly** enough to break the seal between body assembly and the rubber gasket adhering to the bottom of the actuator base plate.
- **For assembly rotation:**
Carefully rotate actuator assembly to the desired position. Reposition the actuator back down onto the adapter base assembly.
- **For assembly replacement:**
Carefully lift the actuator over the spring, which is part of the adapter base assembly.
Position the new actuator over the spring and then carefully lower it back onto the adapter base assembly.
- **Realign holes** in adapter base casting with the corresponding tapped holes in the bottom of the actuator base plate. Be sure the gasket is still in place between the adapter and actuator base plate.
- **Reinsert the adapter bolts** up from the bottom through the adapter and carefully engage threads of the actuator assembly. Tighten securely referring to Table 1 for appropriate torque specifications, see page 18 (Table 1 - Torque Specifications).
- **Reconnect conduit, electrical leads, and all pneumatic lines**, then check that signal switch wands are properly positioned.
Failure to correct any such misalignment can result in extensive damage to the internal mechanism of your valve.
- **Energize valve and cycle several times** from closed to full open position. Also electrically trip the valve in a partially opened position to prove valve operates properly.
- **Replace and secure all cover plates.** Refer to torque values shown on page 18 (Table 1 - Torque Specifications).
- **Verify proper operation** after servicing.

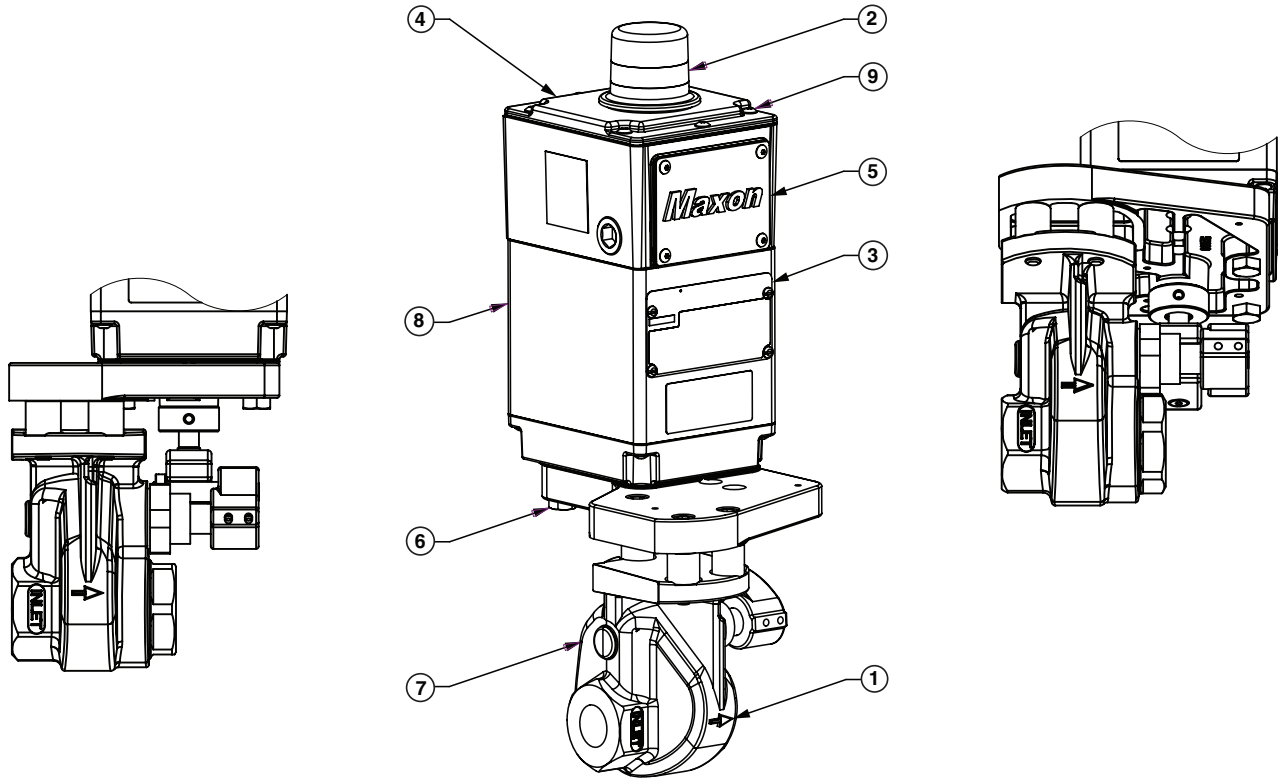

1)	Flow arrow on valve body
2)	Open/shut indicator ¹
3)	Name plate
4)	Switch access cover
5)	Terminal block cover and screws
6)	Actuator/body bolts
7)	Valve body
8)	Actuator assembly
9)	Switch access cover screws

¹ Open/shut indication is 360°. If required, the observation window may be cleaned with a damp cloth.

Field Installation of Valve Position Switch



Instructions below are written for normally-closed shut-off valves.

General: Shut off fuel supply upstream of valve, then de-energize valve electrically.

Remove top cover and terminal block cover to provide access (see page 17 (Component identification), items 4 & 5), being careful not to damage gasket.

See pages 24 (Replacement Switches) and 24 (Add Switches) for instructions on adding or replacing switches.



Substitution of components may affect suitability for Hazardous Locations.

Field Replacement Items

- Position Switches
- Actuators
- Solenoids

Contact MAXON with valve serial numbers to locate appropriate switch kit assembly.

Figure 1: Typical Switch Sub-Assembly

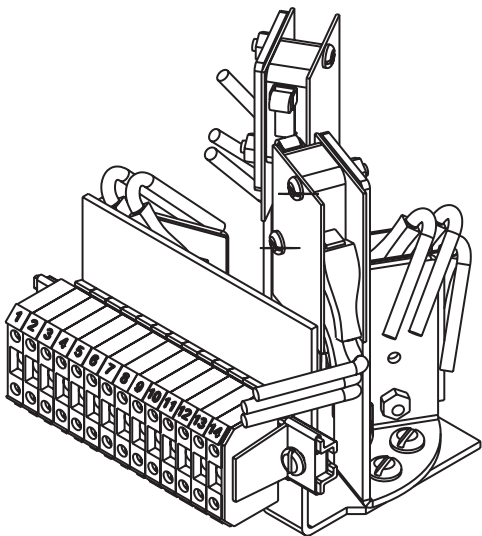

Replacement Switches

- Carefully remove field wiring from the terminal block. Insure field wires are clearly marked to correct terminal.
- Unwire the solenoid valve lead wires from terminals labeled #1 and #2.
- Remove screws that secure the switch sub-assembly to the actuator housing. The switch sub-assembly should be easily removable from actuator assembly (see on page 24 (Figure 1: Typical Switch Sub-Assembly)).

- Note wand position and mounting hole location. Carefully remove the 2 screws and lift existing switch. Reference Figures 2 through 5 (page 10-30.4-45) to ensure correct switch location.
- Install replacement switch in same mounting holes on bracket and verify correct wand position.
- Replace existing wiring one connection at a time, following original route and placement.
- Reassemble switch sub-assembly in actuator housing. Dowel pins are provided to insure proper placement of switch sub-assembly.
- Wire the solenoid valve leads to terminals labeled #1 and #2.
- Cycle valve, checking switch actuation points carefully. VCS switch actuates at top of stem stroke and VOS at bottom for normally-closed shut-off valves.
- Replace covers using torque values shown on page 18 (Table 1 - Torque Specifications), and then re-turn valve to service.

Add Switches

- Carefully remove field wiring from the terminal block. Insure field wires are clearly marked to correct terminal.
- Unwire the solenoid valve lead wires from terminals labeled #1 and #2.
- Remove screws that secure the switch sub-assembly to the actuator housing. The switch sub-assembly should be easily removable from actuator assembly (see on page 24 (Figure 1: Typical Switch Sub-Assembly)).
- Reference Figures 2 through 5 to ensure correct switch location. Valve size is depicted in the model number by the first 4 digits. For example, a 1-1/4" H valve should have Model No. 125H.
- Install switch and insulators, when provided, to correct hole. Insure proper alignment. VCS switch should have activation wand pointed upward and VOS activation wand should be pointed downward.
- Wire new switches to terminals provided.
- Reassemble switch sub-assembly in actuator housing. Dowel pins are provided to insure proper placement of switch sub-assembly.
- Wire the solenoid valve leads to terminals labeled #1 and #2.
- Cycle valve, checking switch actuation points carefully. VCS switch actuates at top of stem stroke and VOS at bottom for normally-closed shut-off valves.

- Replace covers using torque values on page 18 (Table 1 - Torque Specifications), and then return valve to service.

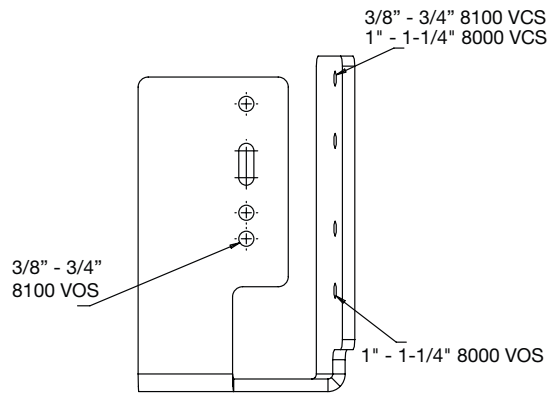

Figure 2: IP67 Switch Bracket

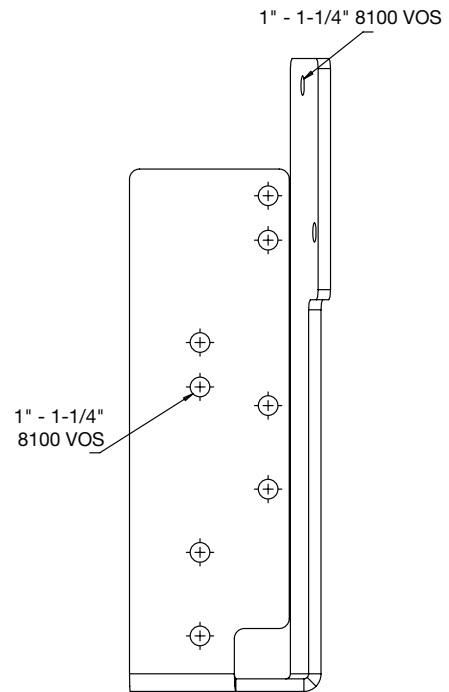

Figure 5: IP67 Switch Bracket

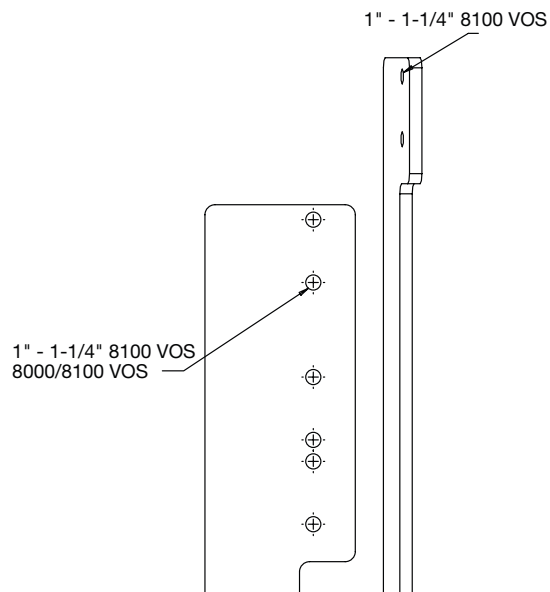

Figure 3: IP67 Switch Bracket

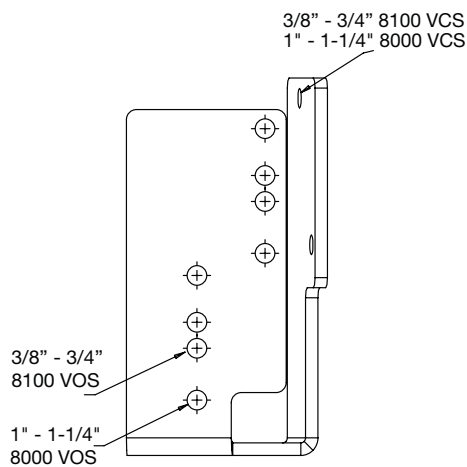

Figure 4: IP67 Switch Bracket

Operating Instructions

Refer to appropriate catalog bulletin and specification page for operating sequence applying to your specific valve. Never operate valve until all essential allied equipment is operative and any necessary purges completed. Failure of valve to operate normally indicates that it is not powered or supply air pressure is not adequate. Check this first!

Main system shut-off should always be accomplished with an upstream leak-tight manual fuel cock.

Normally-closed shut-off valves begin opening cycle immediately upon being powered.

Alternate operator pressures

Series 8000 Valves may be operated within a range of cylinder pressures. Consult charts for application fluid pressure and corresponding required actuator pressure.

Maintenance Instructions

MAXON Series 8000 Valves are endurance tested far in excess of the most stringent requirements of the various approval agencies. They are designed for long life even if frequently cycled, and to be as maintenance-free and trouble-free as possible.

A valve operational test should be performed on an annual basis. If abnormal opening or closing is observed, the valve should be removed from service and your MAXON representative should be contacted. (See Valve Technical Data page 10-35.1.)

Valve leak test should be performed on an annual basis to assure continued safe and reliable operation. Every MAXON valve is operationally tested and meets the requirements of FCI 70-2 Class VI Seat Leakage when in good operable condition. Zero leakage may not be obtained in the field after it has been in service. For specific recommendations on leak test procedures, see MAXON Valve Technical Data page 10-35.2. Any valve that exceeds the allowable leakage, as set forth by your local codes or insurance requirements, should be removed from service and your MAXON representative should be contacted.

Actuator assembly components require no field lubrication and should never be oiled.

Auxiliary switches, solenoids or complete actuator may be replaced in the field.



Do not attempt field repair of valve body or actuator. Any alterations void all warranties and can create potentially hazardous situations.

If foreign material or corrosive substances are present in the fuel line, it will be necessary to inspect the valve to make certain it is operating properly. If abnormal opening or closing is observed, the valve should be removed from service. Contact your MAXON representative for instructions.

Operator should be aware of and observe characteristic opening/closing action of the valve. Should operation ever become sluggish, remove valve from service and contact MAXON for recommendations.



Specific conditions of use:

This equipment includes some external non-metallic parts, including the outer protective coating. The user shall therefore ensure that the equipment is not installed in a location where it may be subjected to external conditions (such as high-pressure steam) which might cause a build-up of electrostatic charges on non-conducting surfaces. Additionally, cleaning of the equipment should be done only with a damp cloth.

Address inquiries to MAXON. Local worldwide offices may be located at www.maxoncorp.com or by phoning 001-765-284-3304. Include valve serial number and nameplate information.

Solenoid replacement procedure

- All power sources both pneumatic and electric must be de-energized and follow all proper safety procedures prior to servicing valve.
- Use a 4 mm allen wrench to remove the top plate. A 3 mm allen wrench is used to remove the terminal block cover.
- Use a 5/16" open end wrench to hold the cylinder shaft, then use a pair of pliers to unthread the switch indicator from the cylinder shaft. When using pliers, grab the switch indicator from the top.

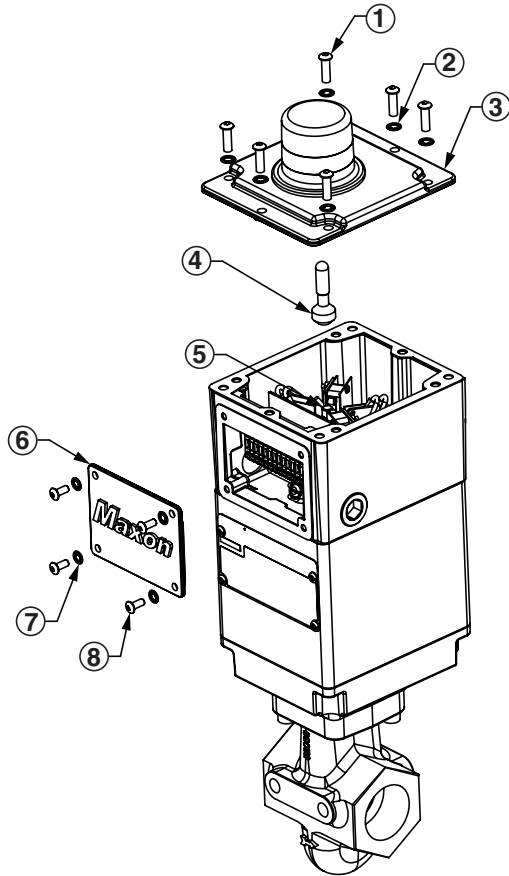

1)	Top plate screw M6 x 20, socket head cap screw
2)	M6 Lock washer
3)	Top plate
4)	Switch indicator
5)	Cylinder shaft
6)	Terminal block cover
7)	M5 Lock washer
8)	Terminal block cover screw M5 x 12, socket head cap screw

- Loosen the liquid tight connector nut where the solenoid wires come into the top housing. Remove #1 and #2 wire from the terminal block.

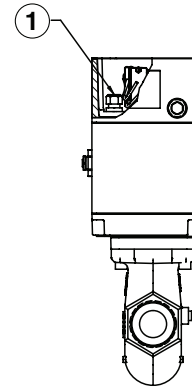

1)	Liquid tight connector
----	------------------------

- Use a 3/4" wrench to remove the solenoid inlet fitting. An adjustable wrench is used to loosen the housing collar. Slightly loosen the housing collar but do not remove, due to the nut and o-ring located inside the housing becoming dislocated.

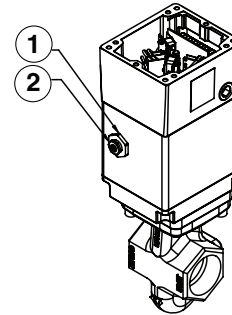

1)	Housing collar
2)	Solenoid inlet fitting

- Use a 4 mm allen wrench and remove the 4 screws that hold the housing to the base plate. Pull the housing straight up and remove. Old solenoid wires will pass through the liquid tight connector.

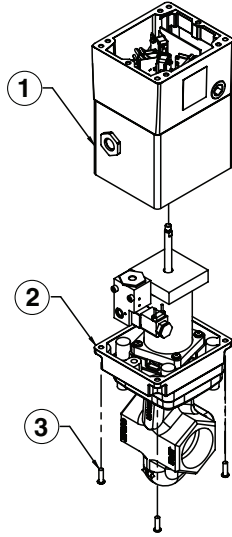

1)	Housing
2)	Base plate
3)	Housing screws M6 x 20 cap screws

- Use a 4 mm allen wrench and remove the 2 screws that hold the solenoid on. Replace the solenoid ensuring that there are 2 o-rings, one on the solenoid inlet and one on the solenoid outlet. The solenoid must be level when tightening screws.

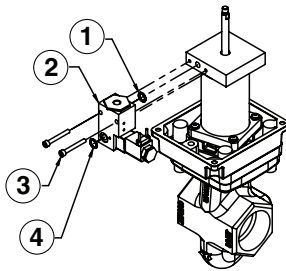

1)	Solenoid o-ring
----	-----------------

2)	Solenoid
3)	M5 x 40 socket head cap screw
4)	Solenoid o-ring

- Run the new solenoid wires back up through the liquid tight connector in the housing and align the cylinder shaft with the hole in the housing. Carefully slide housing back into position. Replace the 4 housing screws and leave loose.
- Verify the o-ring is still on the solenoid inlet by looking through the housing collar. Reinstall solenoid inlet fitting tight. Leave the housing collar loose.
- Reinstall solenoid wire #1 and #2 back to the terminal block and tighten down the liquid tight connector nut.
- A locking sealant must be used on the cylinder shaft threads and then reinstall switch indicator. Make sure to remove any locking sealant that runs down the cylinder shaft. Re-energize pneumatic and electric power and cycle the valve several times to ensure it operates smoothly. Tighten down the 4 housing screws that hold the housing to the base plate using a cross pattern (see on page 18 (Table 1 - Torque Specifications)). Then tighten the housing collar on the solenoid inlet fitting. The o-ring under the housing collar must not be pinched while tightening the housing collar.
- Cycle valve several more times to see if it still operates smoothly. If not, loosen the 4 screws that hold the housing to the base plate and cycle again. Retighten the 4 housing screws. Put the top plate and terminal block covers back on valve (see on page 18 (Table 1 - Torque Specifications)).

For More Information

The Honeywell Thermal Solutions family of products includes Honeywell Combustion Safety, Eclipse, Exothermics, Hauck, Kromschröder and Maxon. To learn more about our products, visit ThermalSolutions.honeywell.com or contact your Honeywell Sales Engineer.

Honeywell MAXON branded products

201 E. 18th Street
Muncie, IN 47302
USA
www.maxoncorp.com

Honeywell Process Solutions

Honeywell Thermal Solutions (HTS)
1250 West Sam Houston Parkway
South Houston, TX 77042

ThermalSolutions.honeywell.com

® U.S. Registered Trademark.
© 2021 Honeywell International Inc.
32M-95005-03 Rev. 08-21
EAC 50112661-001
Printed in U.S.A.

Honeywell